

SUPREME OPTIC-C 1000W 240V DIMMABLE HPS LIGHT - CERAMIC LAMPHOLDER, MANUAL 6-STEP DIMMING

Operating / Electrical parameters

Input voltage Range (AC)	216 V~264 V
Input frequency	50/60 Hz
Voltage performance tolerance (AC)	216 V (240 V@-10%)~264 V (240 V@+10%)
Safety voltage range (AC)	204 V (240 V@-15%)~276 V (240 V@+15%)
Input current operating	4.4 A/5.0 A
Inrush current Peak	≤ 40 A
Line current Harmonics (THD)	≤ 10%@240 V
Power factor	≥ 0.98@240 V
Operating frequency	≥ 100 kHz (at nominal power and input voltage)
Efficiency	≥ 94% (at nominal power and input voltage)

System power

Input power	1050 W
Lamp power	1000 W
Rated lamp power (tolerance)	1000 W (±3%)

Controllability

Control or dimming	Yes
Interface	- Control knob for manual dimming - Manual dimming options

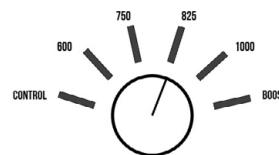

Connector

Input connector	PG watertight connector with 1.5 m cable and EU plug
Lamp holder	Ceramic

Optical parameters

PPF (400-700nm)	>1800 umol/s
Beam angle	120°

Spectrum/Light distribution curve

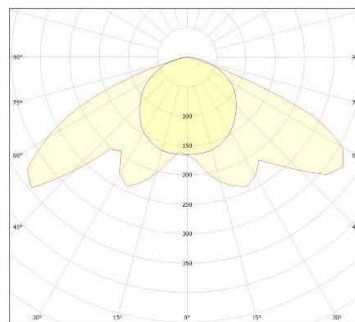
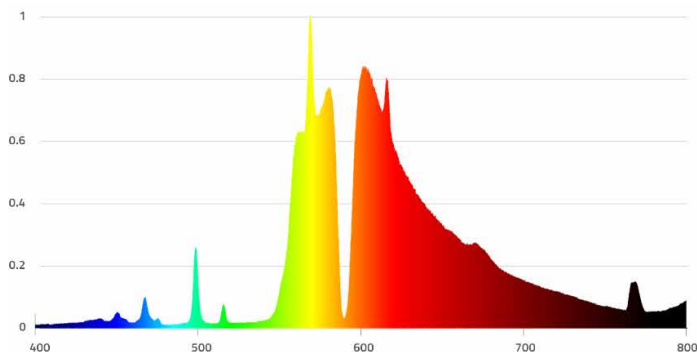

Temperature

Nominal ambient temperature range	0~35°C(Tc)
Storage temperature range	-25~70°C

Approvals and applicable standards

General and safety standards	IEC 60598-1:2020, IEC 60598-2-1:2020
EMC	FCC PART 18 CLASS A
Harmonic	IEC61000-3-2:2014, EN61000-3-3:2013

Protection

Open circuit protection	YES
Short circuit protection	YES
End of life protection	YES (Lamp voltage \geq 330V)
Thermal protection	YES ($T_c \geq 70^\circ\text{C}$)
Over/Under Voltage Protection	YES (@ $U > 110\%U_n$, or $U < 90\%U_n$)
Input protection	FUSE

Mechanical

Dimension L*W*H	602*250*272 mm
Weight	4.8 Kg

Product drawing

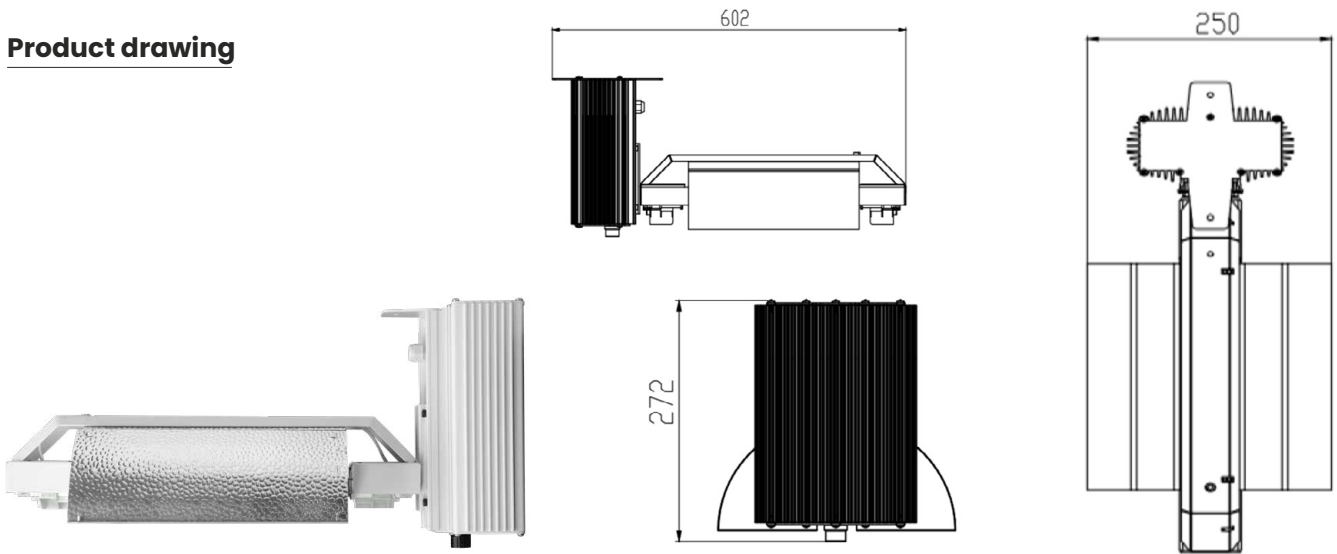

Packing list

- 1x 240V 1000W DE HPS Light
- 2x hanging parts

Box dimension

645*285*290 mm

	Product per packaging (pcs)	Packaging size (mm)	Packaging N.W. (kg)	Packaging G.W. (kg)	Note
Box	1	645*285*290	4.8	6.3	/
Pallet A	48	1310*880*1850	230	317	6 Boxes per layer 8 layers
Pallet B	24	880*670*1850	115	151	3 Boxes per layer 8 layers
40ft Container (HQ)	1032	/	4945	6808	21 Pallet A & 1 Pallet B in one 40ft container

Disclaimer:

1. Please consult to professional electrician before installation.
2. Risk of fire or electric shock: cut off the mains before handling the fixture!
3. Note that it is dangerous to exceed the maximum range of input voltage! It will cause irreversible damage to the product.
4. This product belongs to high-pressure sodium luminaries, please turn off the light 30 minutes before turning on the light again! Otherwise, it will cause irreversible damage to the product!
5. Luminaires need safety grounding protection.